

Metra Non-Ferrous Metals Limited

Unit N7 RD Park
Essex Road
Hoddesdon
Hertfordshire EN11 0FB

Tel: 01992 460 455 Fax: 01992 451 207

e-mail: metz@metra-metals.co.uk

website: www.metzcavitytray.co.uk



Agrément Certificate

22/5997

Product Sheet 1

METZ NON-COMBUSTIBLE CAVITY TRAY

METZ NC-CT

This Agrément Certificate Product Sheet⁽¹⁾ relates to METZ NC-CT, a zinc cavity tray used in the external walls of masonry or steel frame constructions, with a brickwork outer leaf.

(1) Hereinafter referred to as 'Certificate'.

CERTIFICATION INCLUDES:

- factors relating to compliance with Building Regulations where applicable
- factors relating to additional non-regulatory information where applicable
- independently verified technical specification
- assessment criteria and technical investigations
- design considerations
- installation guidance
- regular surveillance of production[†]
- formal three-yearly review.[†]

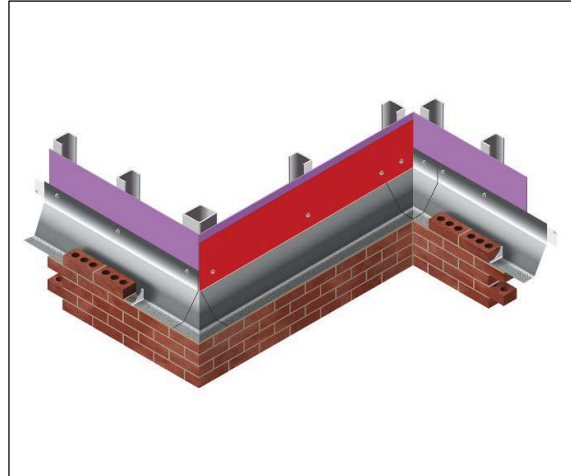

KEY FACTORS ASSESSED

Behaviour in relation to fire — the tray has a reaction to fire classification of A1 without the need for testing, as defined by Commission Decision 96/603/EC and its use is unrestricted by the documents supporting the national Building Regulations (see section 6).

Behaviour under load — the product will not adversely affect the ability of the wall to sustain and transmit compressive loads (see section 7).

Resistance to passage of water — the product will provide an effective barrier against liquid water above the ground damp proof course (dpc) level (see section 8).

Use with cavity wall insulation — the product is compatible with A1 fire-rated materials currently used as cavity wall insulation (see section 9).

Durability — under normal service conditions, the product will remain effective for the lifetime of the building in which they are installed (see section 11).

The BBA has awarded this Certificate to the company named above for the product described herein. This product has been assessed by the BBA as being fit for its intended use provided it is installed, used and maintained as set out in this Certificate.

On behalf of the British Board of Agrément

Date of First issue: 25 January 2022

Hardy Giesler
Chief Executive Officer

This Certificate was amended on 22 May 2024 as part of a transition of The BBA Agrément Certificate scheme delivered under the BBA's ISO/IEC 17020 accreditation. This Certificate was issued originally under accreditation to ISO/IEC 17065. Sections marked with the symbol † are not issued under accreditation. Full conversion to the ISO/IEC 17020 format will take place at the next Certificate review. The BBA is a UKAS accredited Inspection Body (No. 4345). Readers MUST check the validity of this Agrément Certificate by either referring to the BBA website or contacting the BBA directly. Any photographs are for illustrative purposes only, do not constitute advice and must not be relied upon.

British Board of Agrément

Bucknalls Lane
Watford
Herts WD25 9BA

tel: 01923 665300
clientservices@bbacerts.co.uk
www.bbacerts.co.uk

©2022

Regulations

In the opinion of the BBA, METZ NC-CT, if installed, used and maintained in accordance with this Certificate, can satisfy or contribute to satisfying the relevant requirements of the following Building Regulations (the presence of a UK map indicates that the subject is related to the Building Regulations in the region or regions of the UK depicted):



The Building Regulations 2010 (England and Wales) (as amended)

Requirement:	A1	Loading
Comment:		The product can contribute to satisfying this Requirement when properly installed. The presence of a damp-proof course (DPC), however, can reduce the shear and tensile strength of a wall at that location. See section 7 of this Certificate.
Requirement:	B4(1)	External Fire Spread
Comment:		The product is unrestricted under this Requirement. See section 6 of this Certificate.
Requirement:	C2(b)	Resistance to moisture
Comment:		The product can contribute to satisfying this Requirement. See section 8 of this Certificate.
Regulation:	7(1)	Materials and workmanship
Comment:		The product is acceptable. See section 11 and the <i>Installation</i> part of this Certificate
Regulation	7(2)	Materials and workmanship
Comment		The product is unrestricted by this Regulation. See section 6 of this Certificate



The Building (Scotland) Regulations 2004 (as amended)

Regulation:	8(1)	Durability, workmanship and fitness of materials
Comment:		The use of the product can contribute to a construction satisfying this Regulation. See section 11 and the <i>Installation</i> part of this Certificate.
Regulation:	9	Building standards applicable to construction
Standard:	1.1(a)(b)	Structure
Comment:		The product can contribute to a construction satisfying this Standard with reference to clause 1.1.1 ⁽¹⁾⁽²⁾ . The presence of a dpc, however, can reduce the shear and tensile strength of a wall at that location. See section 7 of this Certificate.
Standard:	2.6	Spread on external walls
Comment:		The product is unrestricted under this Standard with reference to clauses 2.6.5 ⁽¹⁾ and 2.6.6 ⁽²⁾ . See section 6 of this Certificate.
Standard:	3.1	Precipitation
Comment:		The product can contribute to a construction satisfying this Standard, with reference to clauses 3.10.1 and 3.10.4. See section 8 of this Certificate.
Standard:	7.1(a)	Statement of sustainability
Comment:		The product can contribute to meeting the relevant requirements of Regulation 9, Standards 1 to 6 and therefore will contribute to a construction meeting a bronze level of sustainability as defined in this Standard.
Regulation:	12	Building standards applicable to conversions
Comment:		Comments in relation to <i>the product</i> under Regulation 9, Standards 1 to 6 also apply to this Regulation, with reference to clause 0.12.1 ⁽¹⁾⁽²⁾ and Schedule 6 ⁽¹⁾⁽²⁾ .

(1) Technical Handbook (Domestic).

(2) Technical Handbook (Non-Domestic).



The Building Regulations (Northern Ireland) 2012 (as amended)

Regulation:	23(a)(i)	Fitness of materials and workmanship
Comment:	(iii)(b)(i)	The product is acceptable. See section 11 and the <i>Installation</i> part of this Certificate.
Regulation:	28(b)	Resistance to moisture
Comment:		The product can contribute to satisfying this Regulation. See section 8 of this Certificate.
Regulation:	30	Stability
Comment:		The product can contribute to satisfying this Regulation. The presence of a dpc, however, can reduce the shear and tensile strength of a wall at that location. See section 7 of this Certificate.
Regulation:	36(a)	External fire spread
Comment:		The product is unrestricted under this Regulation. See section 6 of this Certificate.

Construction (Design and Management) Regulations 2015

Construction (Design and Management) Regulations (Northern Ireland) 2016

Information in this Certificate may assist the client, designer (including Principal Designer) and contractor (including Principal Contractor) to address their obligations under these Regulations.

See sections: 3 *Delivery and site handling* and 14 *Procedure (14.1)* of this Certificate.

Additional Information

NHBC Standards 2022

In the opinion of the BBA, METZ NC-CT, if installed, used and maintained in accordance with this Certificate, can satisfy or contribute to satisfying the relevant requirements in relation to *NHBC Standards*, Chapter 6.1 *External masonry walls* and Chapter 6.10 *Light steel framed walls and floors*.

Technical Specification

1 Description

1.1 METZ NC-CT is a 0.6 mm thick, soft zinc tray Z1 grade to DIN EN 1179. The product is supplied in 10 m rolls, and available in 440 or 600mm widths- See Figure 1 The product is formed and laid in maximum 2000 mm lengths.

1.2 Ancillary items supplied for use with the tray includes:

- METZ Corner Units – 0.6 mm factory-formed and soldered, available for use as both internal and external corners as shown in Figures 2 and 3
- METZ Stop End – 0.6 mm factory-formed and soldered, available for use in both left and right termination of horizontal runs as shown in Figure 4
- METZ adhesive tape – A 100 mm double-sided, acrylate adhesive for use on overlaps
- METZ Sealant – a one part polymer adhesive to seal all exposed edges on the joints
- Metal former tool to bend and form the roll.
- Steel supporting tool as shown in Figure 5.

1.3 Other items used with the product, but outside of the scope of this Certificate, include:

- Weeps for channelling water from the tray to the outside of the brickwork.
- Hand roller
- Tin snips to cut required lengths

- wire brush or wire wool
- Steel screws with plugs for fixing to a blockwork or concrete inner leaf.
- Steel tek screws for fixing to a steel framing system inner leaf

Figure 1 METZ NC-CT Roll



Figure 2 METZ Corner Units (internal)

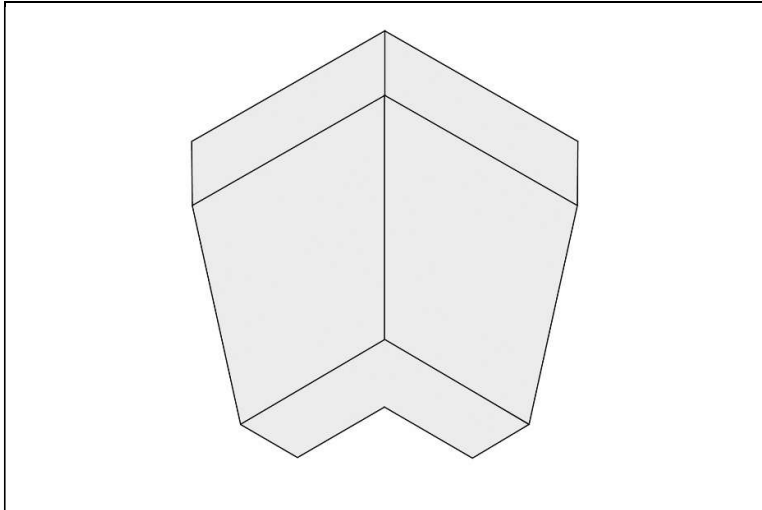

Figure 3 METZ Corner Units (external including integral stop end)

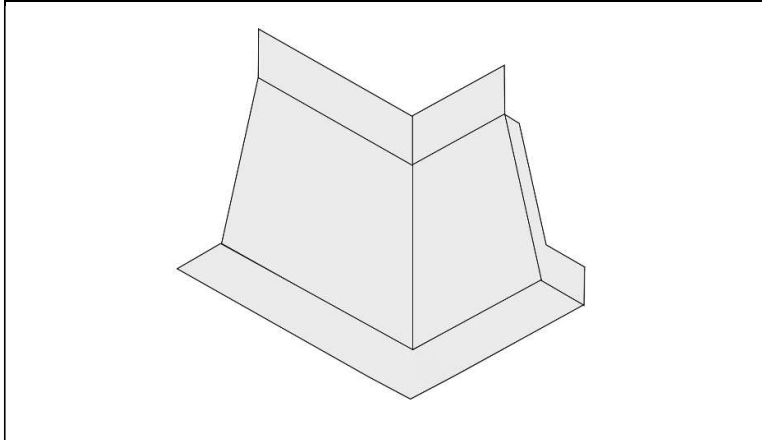

Figure 4 METZ Stop End

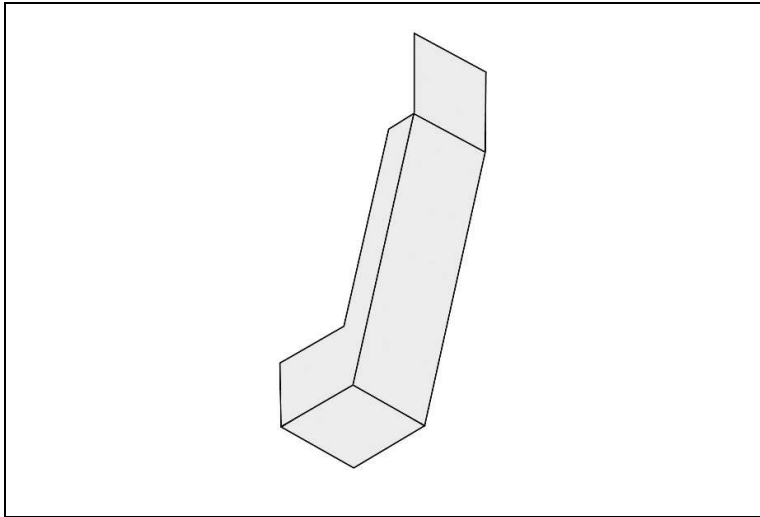
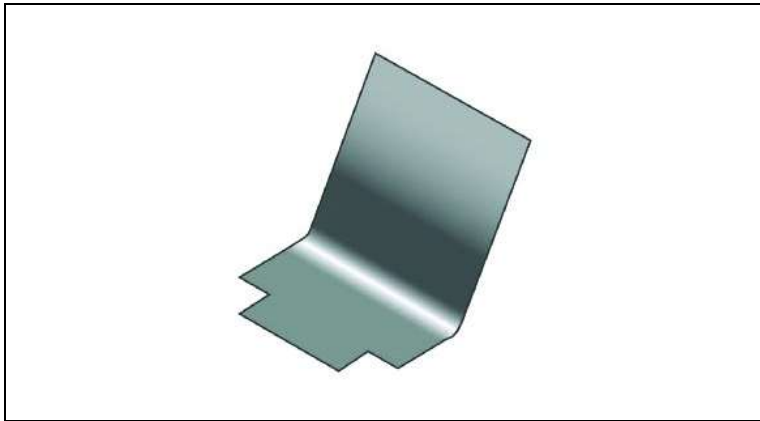

Figure 5 Steel supporting tool



2 Manufacture

2.1 The product is factory formed from soft zinc. Corner units and special shapes are made to order and soldered in the factory to ensure that they are watertight.

2.2 As part of the assessment and ongoing surveillance of product quality, the BBA has:

- agreed with the manufacturer the quality control procedures and product testing to be undertaken
- assessed and agreed the quality control operated over batches of incoming materials
- monitored the production process and verified that it is in accordance with the documented process
- evaluated the process for management of nonconformities
- checked that equipment has been properly tested and calibrated
- undertaken to carry out the above measures on a regular basis through a surveillance process, to verify that the specifications and quality control operated by the manufacturer are being maintained.

3 Delivery and site handling

3.1 The product, along with boxed ancillary items, are delivered to site shrink-wrapped on pallets. Address labels and delivery notes are attached along with envelopes containing customer drawings.

3.2 To prevent damage or surface contamination, the pallets should be unloaded by forklift truck and the products stored in a secure place in the original packaging until required for use.

Assessment and Technical Investigations

The following is a summary of the assessment and technical investigations carried out on METZ NC-CT.

Design Considerations

4 Use

4.1 METZ NC-CT and the associated ancillary items, when specified and installed in accordance with this Certificate and generally with the specifications in PD 6697 : 2019, BS EN 1996-1-2 : 2005, BS EN 1996-2 : 2006, BS EN 1996-3 : 2006 and BS 8215 : 1991, are satisfactory for use as cavity trays in external cavity walls with a brick outer leaf and either a steel framing system (SFS) or a concrete/blockwork inner leaf.

4.2 The external leaf of the cavity walls should be built from standard brickwork with a minimum thickness of 102.5 mm.

5 Practicability of installation

The product is designed to be installed by a competent general builder or bricklayer experienced with these types of products.

6 Behaviour in relation to fire



The product has a reaction to fire classification of A1 without the need for testing, as defined by Commission Decision 96/603/EC and its use is unrestricted by the documents supporting the national Building Regulations.

7 Behaviour under load



The product will not adversely affect the ability of a wall to sustain and transmit compressive loads. However, the presence of a dpc can reduce the shear and tensile (and therefore bending) strengths of a wall. Test walls⁽¹⁾ incorporating the products and tested to BS EN 1052-4 : 2000 gave a Characteristic Shear Strength of 0.083 Nmm⁻², and when tested to DD86-1 : 1983 gave a Characteristic Internal Angle of Friction of 31.81°. The effect of wind and other horizontal or upward forces should be considered at the design stage.

(1) The test walls in these tests used Sunset Red bricks with a tabulated compressive strength of 63 Nmm⁻² and a 1:1:6 mortar with a compressive strength of 4.3 Nmm⁻².

8 Resistance to passage of water



The METZ NC-CT (and associated ancillaries), when sealed together, provide a continuous barrier against liquid water. Water is ejected through weepholes or evaporated from the outer skin.

9 Use with Cavity Wall Insulation

Zinc has no effect on, and is unaffected by, materials currently used as A1 fire-rated cavity wall insulants.

10 Maintenance

As the product is confined within the wall and wall cavity, and has suitable durability (see section 11), maintenance is not required. However, any damage occurring before enclosure must be repaired (see section 15).

11 Durability



Under normal service conditions, the product will remain effective for the life of the building in which it is installed.

12 Reuse and recyclability

The product comprises zinc which can be recycled.

Installation

13 General

13.1 METZ NC-CT must be installed in accordance with the Certificate holder's instructions, PD 6697 : 2019, BS EN 1996-1-1 : 2005, BS EN 1996-2 : 2005, BS EN 1996-3 : 2006, BS 8215 : 1991 and this Certificate.

13.2 The product may be installed at a minimum temperature of 5°C in any weather that permits bricklaying. All relevant surfaces must be clean and dry prior to installing the cavity tray units.

14 Procedure

14.1 METZ Cavity Tray is supplied in 10 m rolls. It is formed and laid in maximum 2000 mm lengths, using tin snips to cut to the required lengths. Appropriate safety gloves should be worn when handling and working.

14.2 Corners are installed and fitted before installing straight lengths.

14.3 METZ Stop Ends are placed in position at the termination of horizontal runs of the METZ-NC-CT.

14.4 The flat tray is laid 10 mm from the edge of the external brick leaf and angled between 10° and 80° to cross the cavity, then a 100 mm vertical upstand is formed to the top edge of tray. The correct shape is formed by using the metal former tool.

14.5 The tray is held in place 10 mm from front edge and the line where the top of the tray meeting the inner wall is marked. Care should be taken to ensure that the wall is dust free and dry before fixing the METZ Adhesive Tape along the marked line using a hand roller. The tray is placed into the correct position to check fitting, then the release strip is removed, and the top of the tray is firmly pressed into place on adhesive strip. Full adhesion is achieved in 20-30 mins.

14.6 All joints are overlapped by 100 mm and bonded using double sided METZ Adhesive Tape. A hand roller is used to ensure that the product has completely bonded. A steel supporting tool is slid under the tray to stabilise it and minimise flexing during bonding (see Figure 6).

14.7 All exposed edges on the joints and top of inner wall must be sealed with METZ Sealant (see Figure 7).

Figure 6 Trays sealed with METZ adhesive tape and supporting tool.

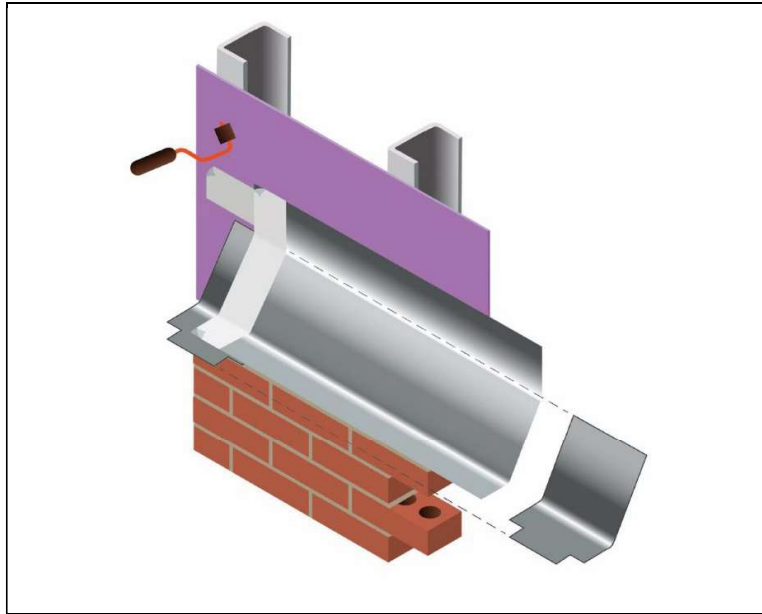

14.8 The tray is fixed to the inner wall using stainless-steel fixings at 450 mm centres along the lengths and above each joint, including all corner joints. Fixings should be centred on each overlap (see Figure 7). The Certificate holder can advise on suitable materials for a particular installation.

14.9 Steps 14.1 to 14.7 are repeated until the installation of the trays is completed.

Figure 7 trays' exposed edges sealed with METZ sealant

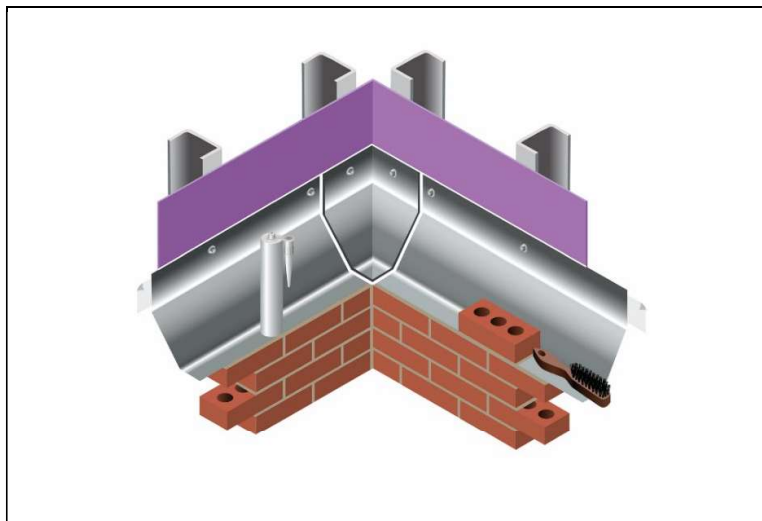

14.10 The surface of the tray which will come into contact with the mortar is scratched with a wire brush or wire wool to provide a key before bricklaying.

14.11 The tray is lifted slightly, and bedding mortar applied to the top layer of bricks. The cavity tray is laid on this mortar base and then construction continued in the usual way.

14.12 Non-combustible weeps are installed at a maximum spacing of 1 metre, unless the trays are to be used with lintels, in which case they are installed at maximum spacing of 450 mm (with the proviso of a minimum of two per lintel (see Figure 8).

Figure 8 External corner, Stop ends and weeps

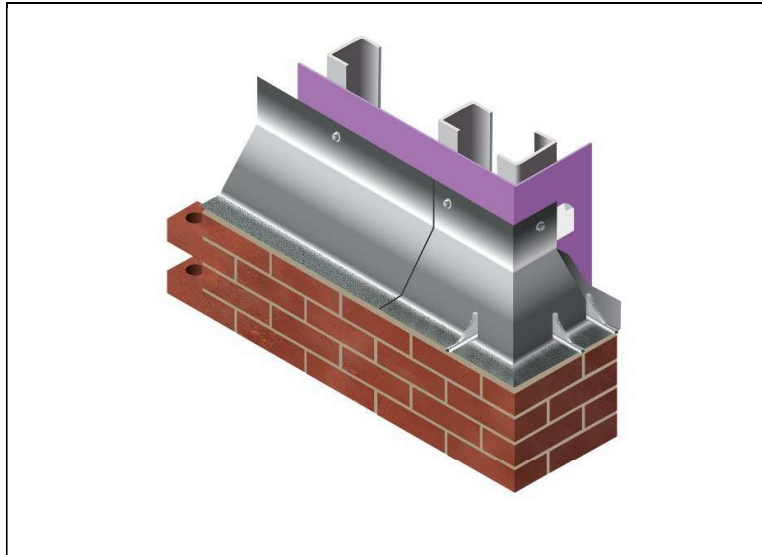

14.13 The product is compatible with 'L' type lintels (see Figure 9). A minimum required lintel projection beyond the face of the cavity closure/vertical dpc of 25 mm should be observed and stop ends should be placed to coincide with perpend joints. Further guidance can be found in the NHBC Standards, Chapter 6.1 (6.1.17) and Technical Guidance Note 6.1/29 S(see Figure 9).

Figure 9 Lintel detail

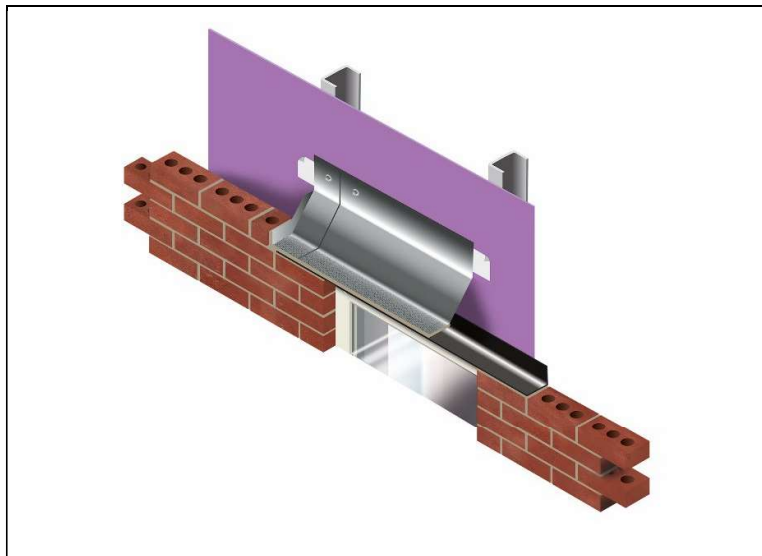

15 Repair

Any damaged trays should be replaced prior to the installation of masonry courses above the tray.

Technical Investigations

16 Tests

Tests were carried out and the results assessed to determine:

- Characteristic shear strength
- Characteristic flexural bond strength
- Overlap shear strength of cavity trays joints after accelerated ageing

- Leakage test carried out on a sample installation
- Fatigue cycling test.

17 Investigations

17.1 The manufacturing process was evaluated, including the methods adopted for quality control, and details were obtained of the quality and composition of the materials used.

17.2 A visit was carried out to a site-in-progress to assess the practicability of installation.

Bibliography

PD 6697 : 2019 *Recommendations for the design of masonry structures to BS EN 1996-1-1 and BS EN 1996-2*

BS EN 1996-1-1 : 2006 + A1 : 2012 *Eurocode 6 – Design of masonry structures – General rules for reinforced and unreinforced masonry structures*

BS EN 1996-1-2 : 2005 *Eurocode 6 – Design of masonry structures – General rules – Structural fire design*

BS EN 1996-2 : 2006 *Design of masonry structures – Design considerations, selection of materials and execution of masonry*

BS EN 1996-3 : 2006 *Eurocode 6 – Design of masonry structures – Simplified circulation methods for unreinforced masonry structures*

BS 8215 : 1991 *Code of practice for design and installation of damp-proof courses in masonry construction*

BS EN 1052-4 : 2000 *Methods of test for masonry – Determination of shear strength including damp proof course*

DD86-1 : 1983 *Damp-proof courses – Methods of test for flexural bond strength and short term shear strength*

DIN EN 1179 *Zinc and zinc alloys – Primary zinc*

Conditions

1. This Certificate:

- relates only to the product that is named and described on the front page
- is issued only to the company, firm, organisation or person named on the front page – no other company, firm, organisation or person may hold or claim that this Certificate has been issued to them
- is valid only within the UK
- has to be read, considered and used as a whole document – it may be misleading and will be incomplete to be selective
- is copyright of the BBA
- is subject to English Law.

2. Publications, documents, specifications, legislation, regulations, standards and the like referenced in this Certificate are those that were current and/or deemed relevant by the BBA at the date of issue or reissue of this Certificate.

3 This Certificate will be displayed on the BBA website, and the Certificate Holder is entitled to use the Certificate and Certificate logo, provided that the product and its manufacture and/or fabrication, including all related and relevant parts and processes thereof:

- are maintained at or above the levels which have been assessed and found to be satisfactory by the BBA
- continue to be checked as and when deemed appropriate by the BBA under arrangements that it will determine
- are reviewed by the BBA as and when it considers appropriate.

4. The BBA has used due skill, care and diligence in preparing this Certificate, but no warranty is provided.

5. In issuing this Certificate the BBA is not responsible and is excluded from any liability to any company, firm, organisation or person, for any matters arising directly or indirectly from:

- the presence or absence of any patent, intellectual property or similar rights subsisting in the product or any other product
- the right of the Certificate holder to manufacture, supply, install, maintain or market the product
- actual installations of the product, including their nature, design, methods, performance, workmanship and maintenance
- any works and constructions in which the product is installed, including their nature, design, methods, performance, workmanship and maintenance
- any loss or damage, including personal injury, howsoever caused by the product, including its manufacture, supply, installation, use, maintenance and removal
- any claims by the manufacturer relating to UKCA, UKNI or CE marking.

6. Any information relating to the manufacture, supply, installation, use, maintenance and removal of this product which is contained or referred to in this Certificate is the minimum required to be met when the product is manufactured, supplied, installed, used, maintained and removed. It does not purport in any way to restate the requirements of the Health and Safety at Work etc. Act 1974, or of any other statutory, common law or other duty which may exist at the date of issue or reissue of this Certificate; nor is conformity with such information to be taken as satisfying the requirements of the 1974 Act or of any statutory, common law or other duty of care.