

Metra Non-Ferrous Metals Limited

Unit N7 RD Park
Essex Road
Hoddesdon
Hertfordshire EN11 0FB

Tel: 01992 460 455 Fax: 01992 451 207

e-mail: metz@metra-metals.co.uk

website: www.metzcavitytray.co.uk



Agrément Certificate

22/5997

Product Sheet 2 Issue 1

METZ NON-COMBUSTIBLE CAVITY TRAY

METZ EAZI-FIT

This Agrément Certificate Product Sheet⁽¹⁾ relates to METZ EaZi-Fit, a zinc cavity tray used in the external walls of masonry or steel frame constructions, with a brickwork outer leaf.

(1) Hereinafter referred to as 'Certificate'.

The assessment includes

Product factors:

- compliance with Building Regulations
- compliance with additional regulatory or non-regulatory information where applicable
- evaluation against technical specifications
- assessment criteria and technical investigations
- uses and design considerations

Process factors:

- compliance with Scheme requirements
- installation, delivery, handling and storage
- production and quality controls
- maintenance and repair

Ongoing contractual Scheme elements†:

- regular assessment of production
- formal 3-yearly review

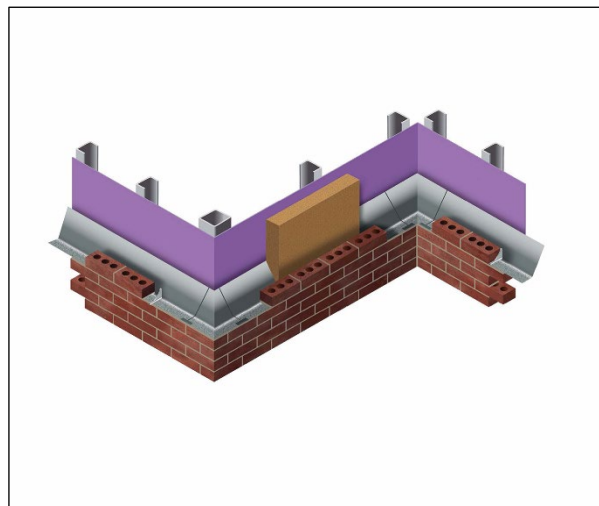

KEY FACTORS ASSESSED

- Section 1. Mechanical resistance and stability
- Section 2. Safety in case of fire
- Section 3. Hygiene, health and the environment
- Section 4. Safety and accessibility in use
- Section 5. Protection against noise
- Section 6. Energy economy and heat retention
- Section 7. Sustainable use of natural resources
- Section 8. Durability

The BBA has awarded this Certificate to the company named above for the product described herein. This product has been assessed by the BBA as being fit for its intended use provided it is installed, used and maintained as set out in this Certificate.

On behalf of the British Board of Agrément

Date of issue: 28 September 2023

Hardy Giesler
Chief Executive Officer

This BBA Agrément Certificate is issued under the BBA's Inspection Body accreditation to ISO/IEC 17020. Sections marked with † are not issued under accreditation.

The BBA is a UKAS accredited Inspection Body (No. 4345), Certification Body (No. 0113) and Testing Laboratory (No. 0357).

Readers MUST check that this is the latest issue of this Agrément Certificate by either referring to the BBA website or contacting the BBA directly.

The Certificate should be read in full as it may be misleading to read clauses in isolation.

Any photographs are for illustrative purposes only, do not constitute advice and should not be relied upon.

British Board of Agrément

1st Floor Building 3
Croxley Park, Watford
Herts WD18 8YG

©2023

tel: 01923 665300
clientservices@bbacerts.co.uk
www.bbacerts.co.uk

SUMMARY OF ASSESSMENT AND COMPLIANCE

This section provides a summary of the assessment conclusions; readers should refer to the later sections of this Certificate for information about the assessments carried out.

Compliance with Regulations

Having assessed the key factors, the opinion of the BBA is that METZ EaZi-Fit, if installed, used and maintained in accordance with this Certificate, can satisfy or contribute to satisfying the relevant requirements of the following Building Regulations:



The Building Regulations 2010 (England and Wales) (as amended)

Requirement:	A1	Loading
Comment:		The product can contribute to satisfying this Requirement when properly installed. The presence of a damp proof course (DPC), however, can reduce the shear and tensile strength of a wall at that location. See section 1 of this Certificate.
Requirement:	B4(1)	External Fire Spread
Comment:		The product is unrestricted under this Requirement. See section 2 of this Certificate.
Requirement:	C2(b)	Resistance to moisture
Comment:		The product can contribute to satisfying this Requirement. See section 3 of this Certificate.
Regulation:	7(1)	Materials and workmanship
Comment:		The product is acceptable. See sections 8 and 9 of this Certificate.
Regulation:	7(2)	Materials and workmanship
Comment:		The product is unrestricted by this Regulation. See section 2 of this Certificate.



The Building (Scotland) Regulations 2004 (as amended)

Regulation:	8(1)	Fitness and durability of materials and workmanship
Comment:		The use of the product can contribute to a construction satisfying this Regulation. See sections 8 and 9 of this Certificate.
Regulation:	9	Building standards - construction
Standard:	1.1(a)(b)	Structure
Comment:		The product can contribute to a construction satisfying this Standard with reference to clause 1.1.1 ⁽¹⁾⁽²⁾ . The presence of a DPC, however, can reduce the shear and tensile strength of a wall at that location. See section 1 of this Certificate.
Standard:	2.6	Spread on external walls
Comment:		The product is unrestricted under this Standard with reference to clauses 2.6.5 ⁽¹⁾ and 2.6.6 ⁽²⁾ . See section 2 of this Certificate.
Standard:	3.1	Precipitation
Comment:		The product can contribute to a construction satisfying this Standard, with reference to clauses 3.10.1 and 3.10.4. See section 3 of this Certificate.
Standard:	7.1(a)	Statement of sustainability
Comment:		The product can contribute to meeting the relevant requirements of Regulation 9, Standards 1 to 6 and therefore will contribute to a construction meeting a bronze level of sustainability as defined in this Standard.

Regulation:	12	Building standards - conversions
Comment:	Comments in relation to the product under Regulation 9, Standards 1 to 6 also apply to this Regulation, with reference to clause 0.12.1 ⁽¹⁾⁽²⁾ and Schedule 6 ⁽¹⁾⁽²⁾ .	
	(1) Technical Handbook (Domestic).	
	(2) Technical Handbook (Non-Domestic).	



The Building Regulations (Northern Ireland) 2012 (as amended)

Regulation:	23(1)(a)(i)	Fitness of materials and workmanship
Comment:	(iii)(b)(i)	The product is acceptable. See sections 8 and 9 of this Certificate.
Regulation:	28(b)	Resistance to moisture
Comment:		The product can contribute to satisfying this Regulation. See section 3 of this Certificate.
Regulation:	30	Stability
Comment:		The product can contribute to satisfying this Regulation. The presence of a DPC, however, can reduce the shear and tensile strength of a wall at that location. See section 1 of this Certificate.
Regulation:	36(a)	External fire spread
Comment:		The product is unrestricted under this Regulation. See section 2 of this Certificate.

Additional Information

NHBC Standards 2023

In the opinion of the BBA, METZ EaZi-Fit, if installed, used and maintained in accordance with this Certificate, can satisfy or contribute to satisfying the relevant requirements in relation to *NHBC Standards*, Chapters 6.1 *External masonry walls* and 6.10 *Light steel framed walls and floors*.

Fulfilment of Requirements

The BBA has judged METZ EaZi-Fit to be satisfactory for use as described in this Certificate. The product has been assessed a cavity tray for use in external cavity walls with a brick outer leaf and either a steel framing system (SFS) or a concrete/blockwork inner leaf.

ASSESSMENT

Product description and intended use

The Certificate holder provided the following description for the product under assessment. METZ EaZi-Fit is a 0.6 mm thick, soft zinc tray, grade Z1 to DIN EN 1179 : 2003. The product is formed on site from 10 m rolls, or 2 m preformed lengths, and is available in widths from 250 to 350 mm, see Figure 1.

Figure 1 METZ EaZi-Fit Roll



Figure 2 METZ Corner Units (internal)

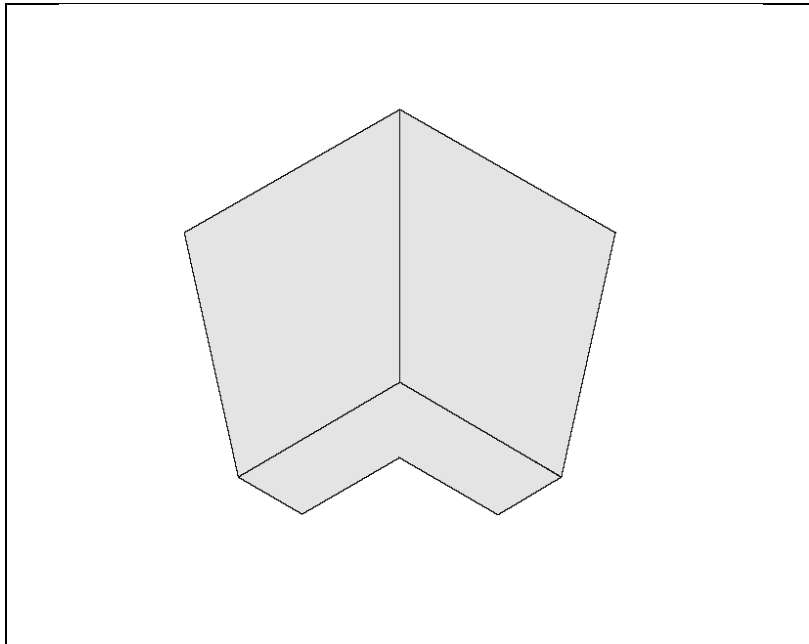

Figure 3 METZ Corner Units (external including integral stop end)

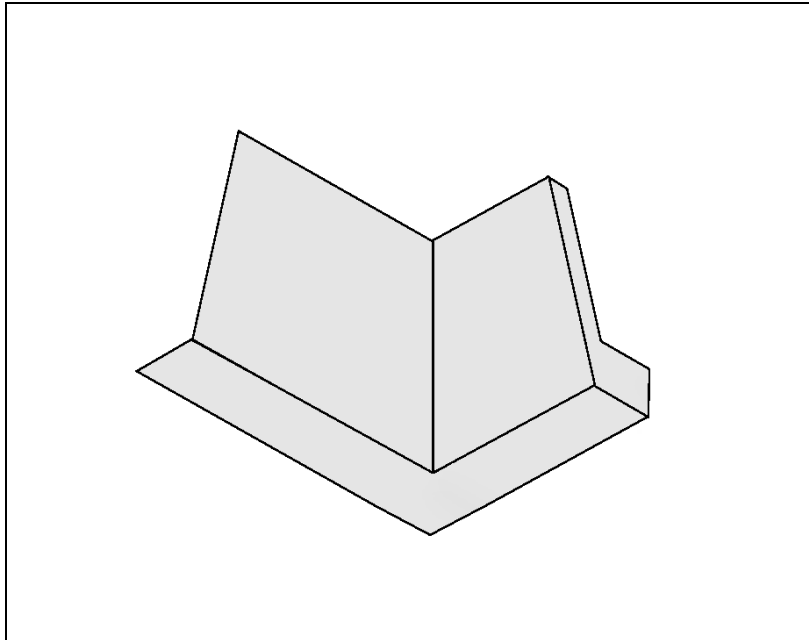
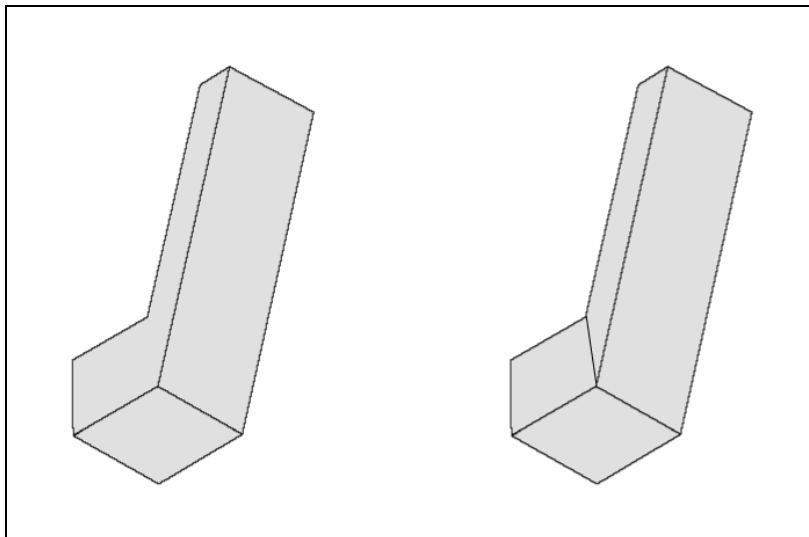

Figure 4 METZ Stop End and METZ Site formed Stop end



Ancillary Items

The following ancillary items are essential to use with the product and have been assessed with the product:

- METZ Corner Units — 0.6 mm factory-formed and soldered, available for use as both internal and external corners as shown in Figures 2 and 3
- METZ Stop End — 0.6 mm factory-formed and soldered, available for use in both left and right termination of horizontal runs as shown in Figure 4
- METZ Site Formed Stop End — 0.6 mm, available for use in both left and right termination of horizontal runs in accordance with sections 9.2.15 to 9.2.17 and as shown in Figure 4
- METZ Adhesive Tape — a 100 mm double-sided, acrylate adhesive for use on overlaps
- metal former tool — to bend and form the roll
- steel supporting tool — as shown in Figure 5.
- METZ EaZi-Fit Clips — zink hooked clips for positioning the tray prior to following brickwork as shown in Figure 6
- METZ Sealant — a one part polymer adhesive to seal all exposed edges on the joints.

The Certificate holder recommends the following ancillary items for use with the product, but these materials have not been assessed by the BBA and are outside the scope of this Certificate:

- weeps — for channelling water from the tray to the outside of the brickwork
- hand roller
- tin snips to cut to required lengths.

Figure 5 Steel supporting tool

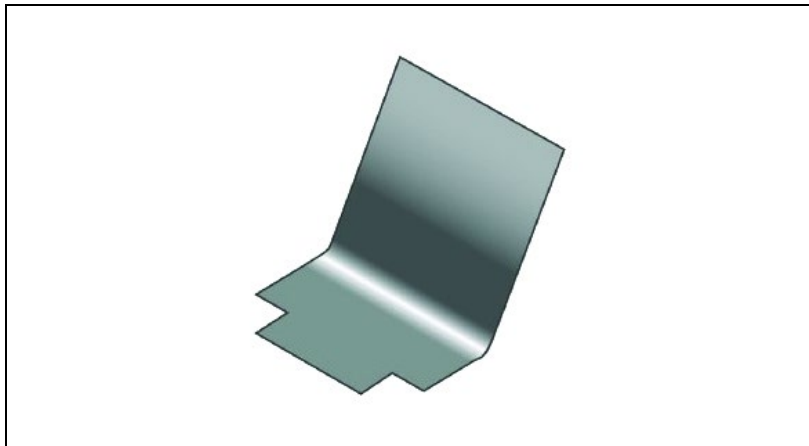
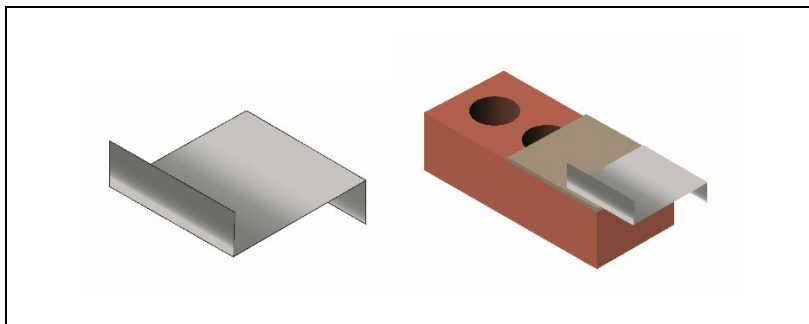

Figure 6 METZ EaZi-Fit Clip



Product assessment – key factors

The product was assessed for the following key factors, and the outcome of the assessments is shown below. Conclusions relating to the Building Regulations apply to the whole of the UK unless otherwise stated.

1 Mechanical resistance and stability

Data were assessed for the following characteristics.

1.1 Properties in relation to loading

1.1.1 Test data relating to loading are given in Table 1.

Table 1 Tests for product loading⁽¹⁾

Product assessed	Assessment method	Requirement	Result
METZ EaZi-Fit	Characteristic shear strength to BS EN 1052-4 : 2000	Value achieved	0.083 N·mm ⁻²
	Characteristic internal angle of friction to DD86-1 : 1983	Value achieved	31.81°

(1) The test walls in these tests used Sunset Red bricks with a tabulated compressive strength of 63 N·mm⁻² and a 1:1:6 mortar with a compressive strength of 4.30 N·mm⁻².

1.1.2 The product will not adversely affect the ability of a wall to sustain and transmit compressive loads. However, the presence of a DPC can reduce the shear and tensile (and therefore bending) strengths of a wall.

1.1.3 METZ EaZi-Fit and the associated ancillary items, when specified and installed in accordance with this Certificate and generally with the specifications in PD 6697 : 2019, BS EN 1996-1-2 : 2005, BS EN 1996-2 : 2006, BS EN 1996-3 : 2006 and BS 8215 : 1991, are satisfactory for use in external cavity walls with a brick outer leaf and either a steel framing system or a concrete/blockwork inner leaf.

2 Safety in case of fire

Data were assessed for the following characteristics.

2.1 Reaction to fire

2.1.1 The trays have a reaction to fire classification of A1 without the need for testing, as defined by Commission Decision 96/603/EC and their use is unrestricted by the documents supporting the national Building Regulations.

2.1.2 The product is unrestricted in terms of building height by the documents supporting the national Building Regulations.

3 Hygiene, health and the environment

Data were assessed for the following characteristics.

3.1 Properties in relation to water

3.1.1 Results of BBA effectiveness of water discharge tests are given in Table 2.

Table 2 Effectiveness of water discharge

Product assessed	Assessment method	Requirement	Result
METZ EaZi-Fit	BBA Method	No water leaks after one hour	Pass

3.1.2 METZ EaZi-Fit and associated ancillaries (such as corner units and stop ends), when sealed together, provide a continuous barrier against liquid water. Water is typically ejected through weepholes or evaporated from the outer skin.

4 Safety and accessibility in use

Not applicable.

5 Protection against noise

Not applicable.

6 Energy economy and heat retention

Not applicable.

7 Sustainable use of natural resources

Data were assessed for the following characteristics.

7.1 Environmental information

The product comprises zinc, which can be recycled.

8 Durability

8.1 The potential mechanisms for degradation and the known performance characteristics of the materials in the product were assessed.

8.2 Specific test data were assessed for the following:

Table 3 Durability testing

Product assessed	Assessment method	Requirement	Result
METZ EaZi-Fit	Overlap shear strength of assemblies to a BBA method	Value achieved	
	Control		
	Heat aged for 56 days at 70°C	No significant degradation	Pass
	Water soak for 56 days at 70°C	No significant degradation	Pass

8.3 Service life

Under normal service conditions, the product will remain effective for the life of the building in which it is installed.

PROCESS ASSESSMENT

Information provided by the Certificate holder was assessed for the following factors:

9 Design, installation, workmanship and maintenance

9.1 Design

9.1.1 METZ EaZi-Fit must be installed in accordance with this Certificate, the Certificate holder's instructions, and generally in accordance with PD 6697 : 2019, BS EN 1996-1-1 : 2005, BS EN 1996-2 : 2005, BS EN 1996-3 : 2006 and BS 8215 : 1991.

9.1.2 The products may be installed at a minimum temperature of 5°C in any weather that permits bricklaying. All relevant surfaces must be clean and dry prior to installing the product.

9.1.3 The external leaf of the cavity walls must be built from standard brickwork with a minimum thickness of 102.5 mm.

9.1.4 The zinc sheets are available in widths from 250 to 350 mm, to suit total cavities from 160 to 330 mm ensuring a minimum cavity width coverage of 75%.

9.2 Installation

9.2.1 Installation instructions provided by the Certificate holder were assessed and judged to be appropriate and adequate.

9.2.2 Installation must be carried out in accordance with this Certificate and the Certificate holder's instructions.

9.2.3 Tin snips must be used to cut the supplied rolls to the required length, with a maximum of 2000 mm. Appropriate safety gloves must be worn when handling and working.

9.2.4 METZ Stop Ends must be placed in position at the termination of horizontal runs of the METZ EaZi-Fit.

9.2.5 METZ Eazi Clips are placed in position at the joints, a bed of 5 mm mortar is then placed onto the outer brickwork and around the METZ Eazi Clips. A flat tray is laid 3 mm from the edge of the external brick leaf and angled between 10 and 80° to cross the cavity. The whole assembly is held in place on the 5 mm bed of mortar on the brickwork and by the METZ Eazi Clips, see Figure 7.

9.2.6 The tray is held in place by METZ Eazi Clips 3 mm from front edge. The tray is placed into the correct position to check fitting, then the release strip is removed, and the top of the tray is firmly pressed into place on adhesive strip. Full adhesion is achieved in 20 to 30 minutes.

Figure 7 Trays placed onto outer skin and held by clips

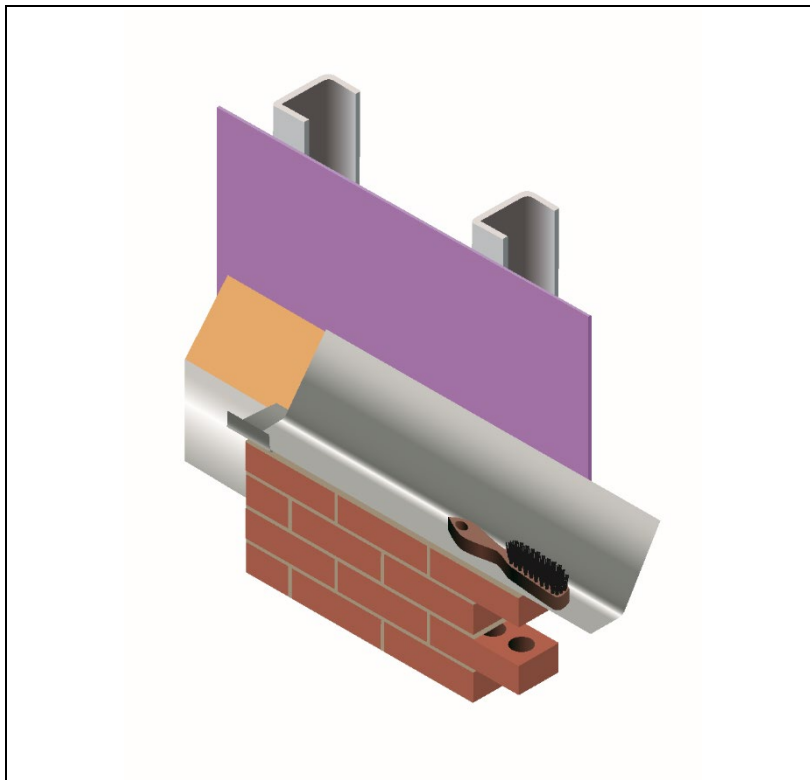

9.2.7 All joints are overlapped by 100 mm and bonded using double sided METZ Adhesive Tape. A hand roller is used to ensure that the product has completely bonded. A steel supporting tool is slid under the tray to stabilise it and minimise flexing during bonding (see Figure 8).

Figure 8 Trays placed onto outer skin and held by clips

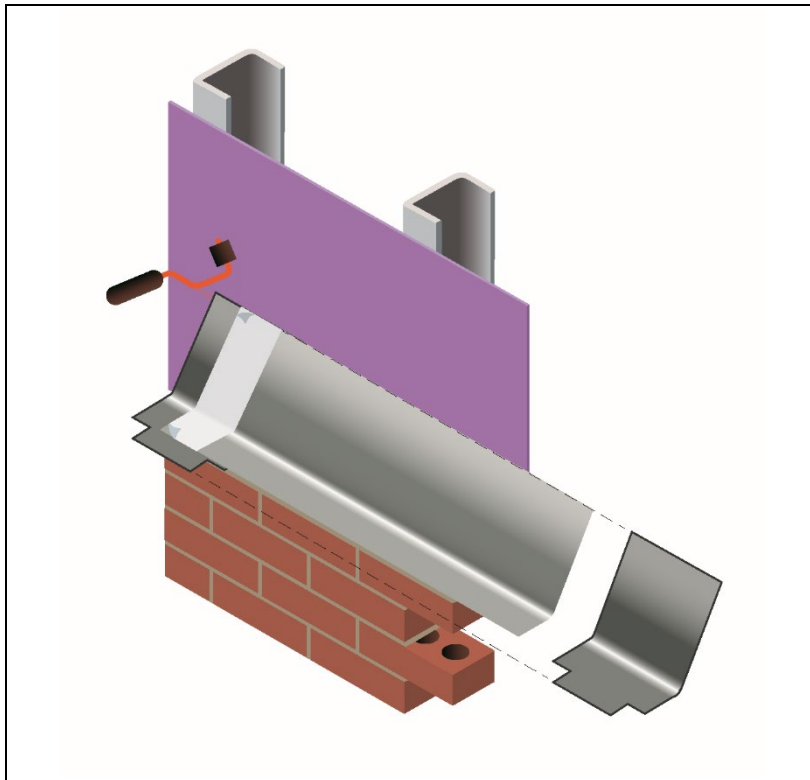

9.2.8 All exposed edges on the joints must be sealed with METZ Sealant (see Figure 9).

9.2.9 Sections 9.2.3 to 9.2.8 are repeated until the installation of the trays is completed.

Figure 9 Trays' exposed edges sealed with METZ Sealant

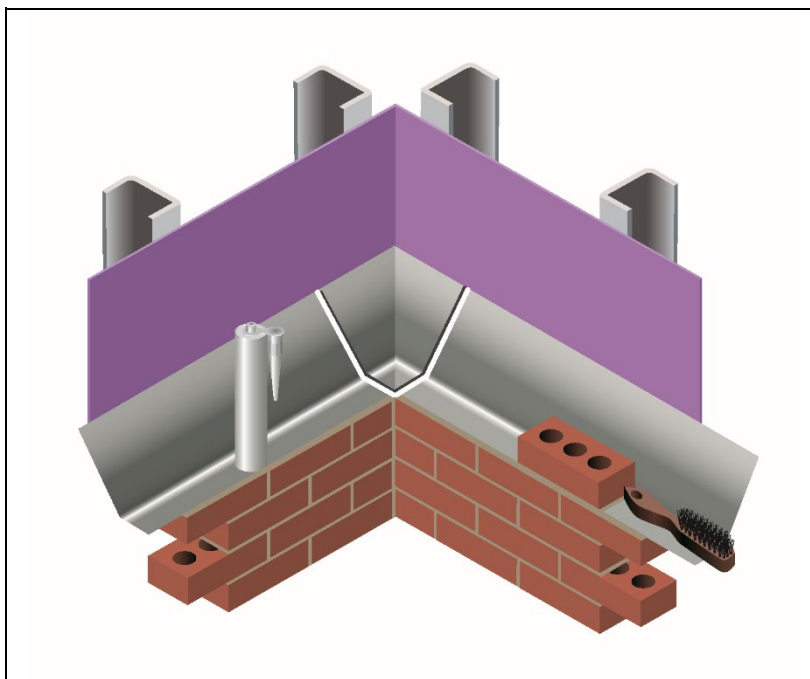

9.2.10 The surface of the tray which will come into contact with the mortar is scratched with a wire brush or wire wool to provide a key before bricklaying.

9.2.11 The tray is lifted slightly, and bedding mortar applied to the top layer of bricks. The cavity tray is laid on this mortar base and then construction continued in the usual way.

9.2.12 Non-combustible weeps are installed at a maximum spacing of 1 metre, unless the trays are to be used with lintels, in which case they are installed at maximum spacing of 450 mm (with the proviso of a minimum of two per lintel (see Figure 10).

Figure 10 External corner, stop ends and weeps

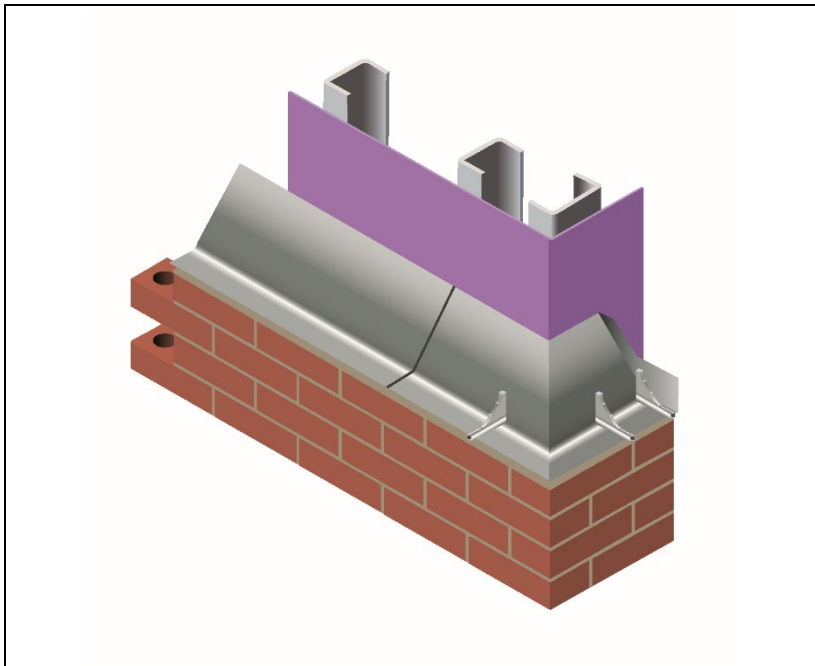

9.2.13 The product is compatible with 'L' type lintels (see Figure 11). A minimum required lintel projection beyond the face of the cavity closure/vertical DPC of 25 mm must be observed and stop ends must be placed to coincide with perpend joints. Further guidance can be found in the *NHBC Standards 2023*, Chapter 6.1 (6.1.17) and *NHBC Technical Guidance Note 6.1/29 Forming stop ends to cavity trays*, see Figure 11.

Figure 11 Lintel detail

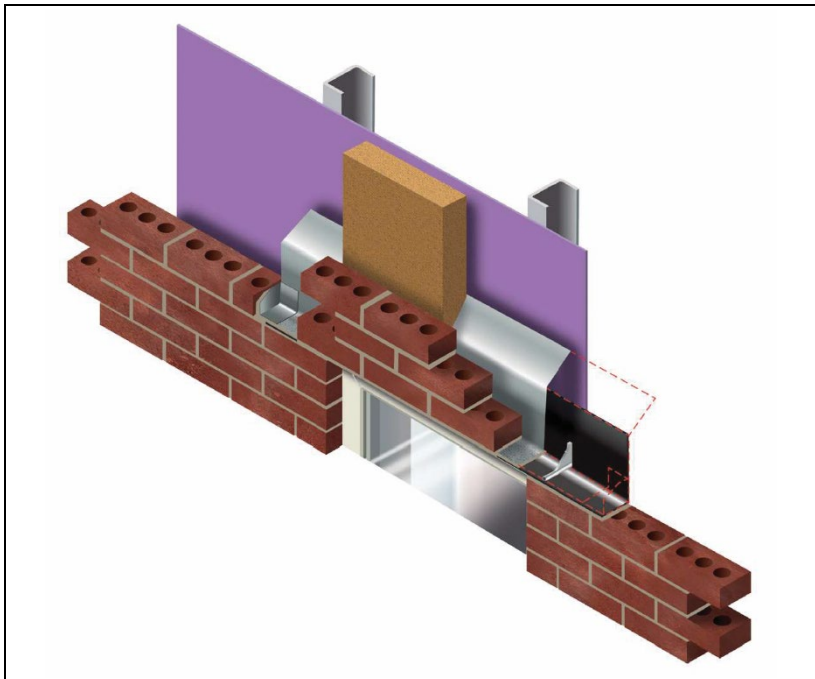

9.2.14 Site formed stop ends, are produced by cutting, with supplied snips, 130 mm of METZ roll to create a rectangle. The 100 mm lower part of the stop end is formed using the bending tool to form the outer edge. The bending tool is then used to form a 30 mm upstand on either the left or right edge, see Figure 12.

Figure 12 Forming site formed stop end detail

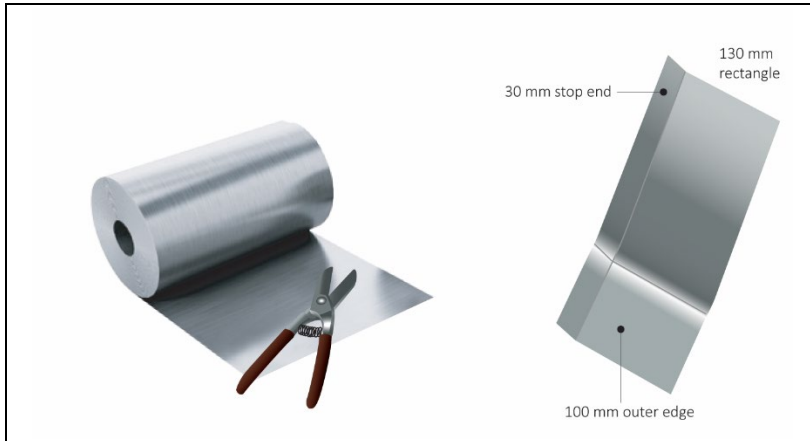

9.2.15 Pliers are positioned on the outer leg area and used to twist the strip to form the stop end. Twisting this area will start to lift the tray into position, see Figure 13.

Figure 13 Cutting site formed stop end detail

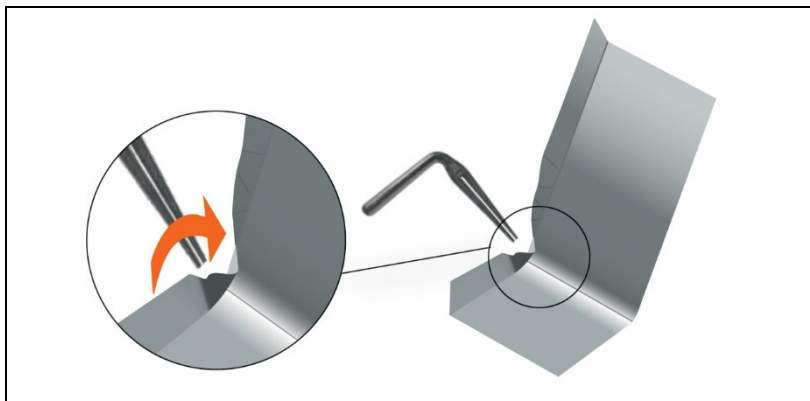

9.2.16 The twisted strip is flattened using a rubber mallet to complete the stop end shape, see Figure 14.

Figure 14 Finishing site formed stop end detail

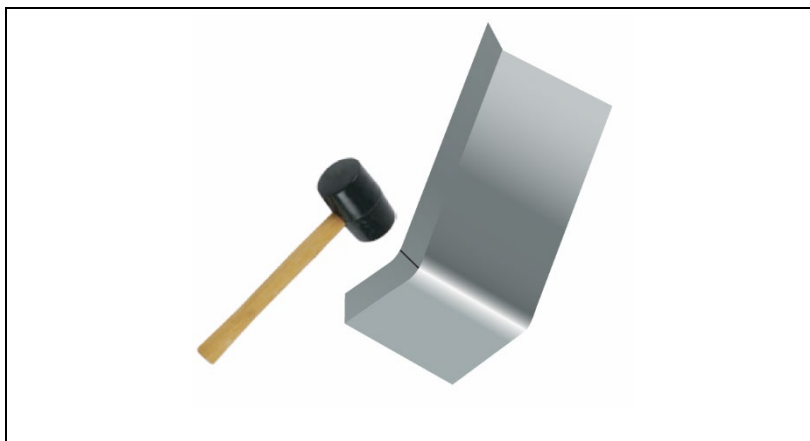

9.3 Workmanship

Practicability of installation was assessed by the BBA on the basis of the Certificate holder's information and a site visit to witness an installation in progress. To achieve the performance described in this Certificate, installation of the product must be carried out by a competent general builder or bricklayer familiar with this type of product.

9.4 Maintenance and repair

As the product is confined within the wall and wall cavity, and has suitable durability (see section 8), maintenance is not required. However, any damage occurring before enclosure must be repaired.

10 Manufacture

10.1 The production processes for the product have been assessed, and provide assurance that the quality controls are satisfactory according to the following factors:

10.1.1 The manufacturer has provided documented information on the materials, processes, testing and control factors.

10.1.2 The quality control operated over batches of incoming materials has been assessed and deemed appropriate and adequate.

10.1.3 The quality control procedures and product testing to be undertaken have been assessed and deemed appropriate and adequate.

10.1.4 The process for management of non-conformities has been assessed and deemed appropriate and adequate. An audit of each production location was undertaken, and it was confirmed that the production process was in accordance with the documented process, and that equipment has been properly tested and calibrated.

† 10.2 The BBA has undertaken to review the above measures on a regular basis through a surveillance process, to verify that the specifications and quality control operated by the manufacturer are being maintained.

11 Delivery and site handling

11.1 The Certificate holder stated that the product, along with boxed ancillary items, is delivered to site shrink-wrapped on pallets. Address labels and delivery notes are attached along with envelopes containing customer drawings.

11.2 To prevent damage or surface contamination, the pallets must be unloaded by forklift truck and the products must be stored in a secure dry place in the original packaging until required for use.

ANNEX A – SUPPLEMENTARY INFORMATION †

Supporting information in this Annex is relevant to the product but has not formed part of the material assessed for the Certificate.

Construction (Design and Management) Regulations 2015

Construction (Design and Management) Regulations (Northern Ireland) 2016

Information in this Certificate may assist the client, designer (including Principal Designer) and contractor (including Principal Contractor) to address their obligations under these Regulations.

Additional information on installation

Zinc has no effect on, and is unaffected by, materials currently used as A1 fire-rated cavity wall insulants. However, where the trays are not bonded to the inner leaf, they do not form a continuous mechanical barrier, and blown or injected insulation may penetrate from the cavity above to below the trays. This possibility must be considered when an in-situ applied cavity insulation is used.

In addition to section 11.1, customer drawings can be provided with the product if requested.

Bibliography

BS EN 1052-4 : 2000 *Methods of test for masonry – Determination of shear strength including damp proof course*

BS EN 1996-1-1 : 2005 + A1 : 2012 *Eurocode 6 – Design of masonry structures – General rules for reinforced and unreinforced masonry structures*

BS EN 1996-1-2 : 2005 *Eurocode 6 – Design of masonry structures – General rules – Structural fire design*

BS EN 1996-2 : 2006 *Design of masonry structures – Design considerations, selection of materials and execution of masonry*

BS EN 1996-3 : 2006 +A1 2014 *Eurocode 6 – Design of masonry structures – Simplified circulation methods for unreinforced masonry structures*

BS 8215 : 1991 *Code of practice for design and installation of damp-proof courses in masonry construction*

DIN EN 1179 : 2003 *Zinc and zinc alloys — Primary zinc*

DD86-1 : 1983 *Damp-proof courses — Methods of test for flexural bond strength and short term shear strength*

PD 6697 : 2019 *Recommendations for the design of masonry structures to BS EN 1996-1-1 and BS EN 1996-2*

Conditions of Certificate

Conditions

1 This Certificate:

- relates only to the product that is named and described on the front page
- is issued only to the company, firm, organisation or person named on the front page – no other company, firm, organisation or person may hold or claim that this Certificate has been issued to them
- is valid only within the UK
- has to be read, considered and used as a whole document – it may be misleading and will be incomplete to be selective
- is copyright of the BBA
- is subject to English Law.

2 Publications, documents, specifications, legislation, regulations, standards and the like referenced in this Certificate are those that were current and/or deemed relevant by the BBA at the date of issue or reissue of this Certificate.

3 This Certificate will be displayed on the BBA website, and the Certificate Holder is entitled to use the Certificate and Certificate logo, provided that the product and its manufacture and/or fabrication, including all related and relevant parts and processes thereof:

- are maintained at or above the levels which have been assessed and found to be satisfactory by the BBA
- continue to be checked as and when deemed appropriate by the BBA under arrangements that it will determine
- are reviewed by the BBA as and when it considers appropriate.

4 The BBA has used due skill, care and diligence in preparing this Certificate, but no warranty is provided.

5 In issuing this Certificate the BBA is not responsible and is excluded from any liability to any company, firm, organisation or person, for any matters arising directly or indirectly from:

- the presence or absence of any patent, intellectual property or similar rights subsisting in the product or any other product
- the right of the Certificate holder to manufacture, supply, install, maintain or market the product
- actual installations of the product, including their nature, design, methods, performance, workmanship and maintenance
- any works and constructions in which the product is installed, including their nature, design, methods, performance, workmanship and maintenance
- any loss or damage, including personal injury, howsoever caused by the product, including its manufacture, supply, installation, use, maintenance and removal
- any claims by the manufacturer relating to UKCA marking and CE marking.

6 Any information relating to the manufacture, supply, installation, use, maintenance and removal of this product which is contained or referred to in this Certificate is the minimum required to be met when the product is manufactured, supplied, installed, used, maintained and removed. It does not purport in any way to restate the requirements of the Health and Safety at Work etc. Act 1974, or of any other statutory, common law or other duty which may exist at the date of issue or reissue of this Certificate; nor is conformity with such information to be taken as satisfying the requirements of the 1974 Act or of any statutory, common law or other duty of care.

British Board of Agrément

1st Floor Building 3
Croxley Park, Watford
Herts WD18 8YG

©2023

tel: 01923 665300
clientservices@bbacerts.co.uk
www.bbacerts.co.uk